

10th Class 2016

Physics	Group-I	Paper-II
Time: 15 Minutes	(Objective Type)	Max. Marks: 12

Note: Four possible answers A, B, C and D to each question are given. The choice which you think is correct, fill that circle in front of that question with Marker or Pen ink in the answer-book. Cutting or filling two or more circles will result in zero mark in that question.

1-1- **e-mail is abbreviation of:**

- (a) Emergency mail (b) Electronic mail ✓
 (c) Urgent mail (d) None of these

2- **In which process, sun gains energy:**

- (a) Nuclear fission (b) Nuclear fusion ✓
 (c) Burning of gases (d) Chemical reaction

3- **The equation of Not Operation is:**

- (a) $X = A.B$ (b) $X = A + B$
 (c) $X = A - B$ (d) $X = \bar{A}$ ✓

4- **Frequency is equal to:**

- (a) $f = \frac{1}{T}$ ✓ (b) $f = \frac{l}{g}$
 (c) $f = 2\pi \sqrt{\frac{l}{g}}$ (d) $f = kx$

5- **The refractive index of ice is:**

- (a) 1.00 (b) 1.33
 (c) 1.31 ✓ (d) 2.42

6- **The unit of electric intensity is:**

- (a) Watt (b) Ns^{-1}
 (c) NC^{-1} ✓ (d) Nm

7- **Transformer is used for:**

- (a) Increase voltage ✓ (b) Increase resistance
 (c) Both a & b (d) None of these

8- One mega byte is equal to:

- (a) 1024 kB ✓ (b) 1035 kB
(c) 1044 kB (d) 1054 kB

9- The spring's constant is:

- (a) $k = \frac{-F}{x}$ ✓ (b) $F = ma$
(c) $w = mg$ (d) $k = -\frac{x}{m}$

10- Mathematical form of current is:

- (a) $I = \frac{t}{Q}$ (b) $I = \frac{Q}{t}$ ✓
(c) $I = QR$ (d) $I = VR$

11- The electroscope is an instrument which is used for:

- (a) Detecting charge ✓ (b) Detecting current
(c) Detecting radiations (d) None of these

12- The speed of sound in air at 0°C is:

- (a) 317 ms⁻¹ (b) 346 ms⁻¹
(c) 386 ms⁻¹ (d) 331 ms⁻¹ ✓

10th Class 2016

Physics	Group-I	Paper-II
Time: 2.45 Hours	(Subjective Type)	Max. Marks: 63

(Part-I)**2. Write short answers to any Six (6) questions: 12**

(i) **Define refraction of waves.**

Ans The change of path of waves while passing from one medium into another medium, a part of it returns back in the same medium is called refraction of waves.

(ii) **Define quality of sound.**

Ans The characteristic of sound by which two sound waves of same loudness, and pitch are distinguished from each other is called quality of sound.

(iii) **What is meant by echo of sound?**

Ans When sound is incident on the surface of a medium, it bounces into the first medium. This phenomenon is called echo 'or' reflection of sound.

(iv) **What is meant by "Sonar"?**

Ans Ultrasound is used to locate underwater depths or is used for locating objects lying deep on the ocean floor, etc. The technique is called SONAR.

(v) **What is the difference between convex mirror and concave mirror?**

Ans A spherical mirror whose inner curved surface is reflecting is called concave mirror while a spherical mirror whose outer curved surface is reflecting is called convex mirror.

(vi) **Write medical use of light pipe.**

Ans Light pipe is used to illuminate the inaccessible places by the doctors or engineers. For example, doctors view inside the human body. They can also used to transmit images from one place to another.

(vii) **What is meant by power of lenses? What is its unit?**

Ans "The reciprocal of focal length of a lens in metres is known as **power of lens.**"

Unit:

SI unit of power of a lens is Diopetre. It is denoted by D.

Diopetre:

It is power of lens whose focal length is one metre.

(viii) What is electroscope?

Ans An electroscope is an early scientific instrument that is used to detect the presence of electric charge on a body.

(ix) How can be conductors and insulators identified by electroscope?

Ans Electroscope can be used to distinguish between insulators and conductors. Touch the disc of a charged electroscope with material under test. If the leaves collapse from their diverged position, the body would be a good conductor. If there is no change in the divergence of the leaves, it will show that the body under test is an insulator.

3. Write short answers to any Five (5) questions: 10

(i) Define variable capacitor and fixed capacitor.

Ans "In variable capacitors, the value of capacitance can be increased or decreased." Whereas

"In fixed type capacitors, the value of capacitance cannot be changed."

(ii) Write two uses of capacitor.

Ans Following are the two uses of capacitor:

1. They are used for tuning transmitters, receivers and transistor radios.
2. They are used to distinguish between high and low frequency signals.

(iii) What is meant by ohmic and non-ohmic conductors?

Ans Materials that obey Ohm's law, and hence have a constant resistance over a wide range of voltages, are

said to be ohmic. Materials having resistance that changes with voltage or current are non-ohmic.

(iv) **Define Farad.**

Ans If one coulomb of charge given to the plates of a capacitor produces a potential difference of one volt between the plates of the capacitor, then its capacitance would be one 'Farad'.

(v) **What is meant by earth wire?**

Ans Many electrical appliances have metal cases; including cookers, washing machines and refrigerators. The earth wire provides a safe route for the current to flow through, if the live wire touches the casing.

(vi) **Define Ampere.**

Ans If one coulomb of charge passes through any cross section in one second, then current will be equal to one ampere.

(vii) **What is electric current? Write its formula to calculate it.**

Ans **Current:**

The rate of flow of electric charge through any cross-sectional area is called electric current.

Its formula is:

$$I = \frac{Q}{t}$$

Unit: Its SI unit is Ampere (A).

(viii) **What is meant by mutual induction?**

Ans **Mutual Induction:**

The phenomenon of production of induced current in one coil due to change of current in a neighbouring coil is called mutual induction.

4. Write short answers to any Five (5) questions: 10

(i) **Define electromagnetic induction.**

Ans The production of an electric current across a conductor moving through a magnetic field is called electromagnetic induction.

(ii) Define digital electronics.

Ans The branch of 'Applied Physics' which discusses those principles and ways by means of which we control the flow of electrons using different devices is called digital electronics.

(iii) Write the parts of cathode ray oscilloscope.

Ans Following are the parts of cathode ray oscilloscope:

1. The electron gun with control grid.
2. The deflecting plates.
3. A fluorescent screen.

(iv) What is global web?

Ans Internet is a global web of more than several million nets in which more than 50 million computers are operating and several millions people participate through the world.

(v) What is flash drive?

Ans A flash drive is a small storage device that can be used to transport files from one computer to another.

(vi) What is hard disk?

Ans A hard disk is a rigid, magnetically sensitive disk that spins rapidly and continuously inside the computer chassis or in a separate box connected to the computer housing.

(vii) What is neutron number?

Ans The neutron number (N) is equal to the number of neutrons in the nucleus.

(viii) Define isotopes.

Ans "The atoms of an element which have same atomic number but different atomic mass number are **isotopes**."

e.g., Hydrogen has three isotopes:

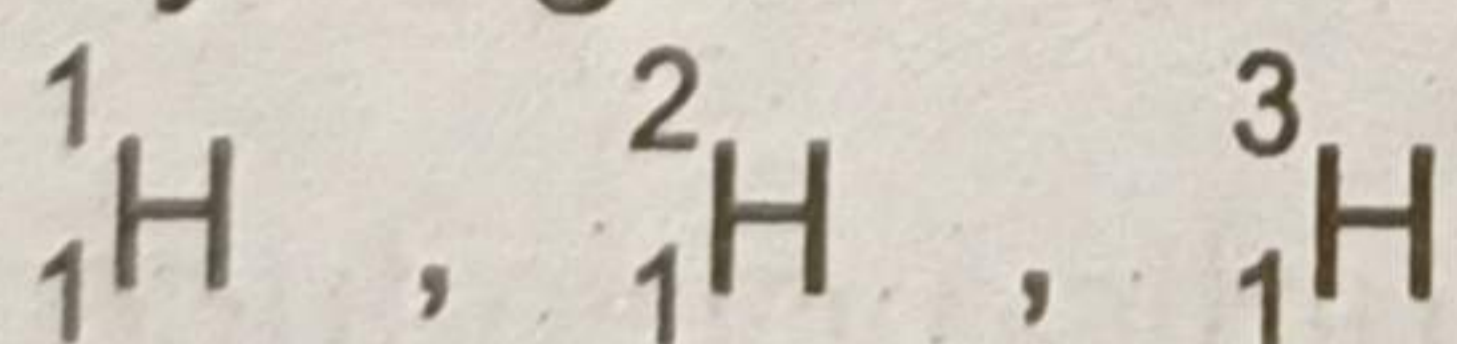

(Part-II)

NOTE: Attempt any Three (3) questions.

Q.5.(a) What are damped oscillations? Explain it. (4)

Ans Damped Oscillations:

The oscillations of a system in the presence of some resistive force are damped oscillations.

Explanation:

Vibratory motion of ideal systems in the absence of any friction or resistance continues indefinitely under the action of a restoring force. Practically, in all systems, the force of friction retards the motion, so the systems do not oscillate indefinitely. The friction reduces the mechanical energy of the system as time passes, and the motion is said to be damped. This damping progressively reduces the amplitude of the vibration of motion as shown in the following figure.

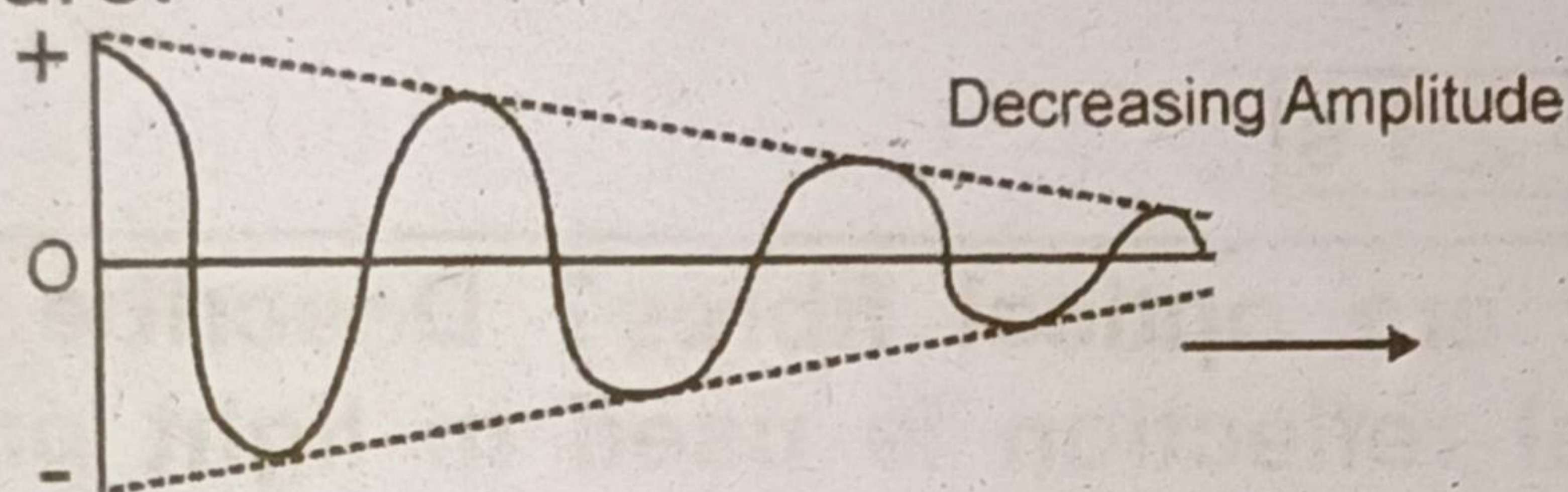

Shock absorbers in automobiles are one practical application of damped motion. A shock absorber consists of a piston moving through a liquid. The upper part of the shock absorber is firmly attached to the body of the car. When the car travels over a bump on the road, the car may vibrate violently. The shock absorbers damp these vibrations and convert their energy into heat energy of the oil.

- (b) A sound wave has a frequency of 20 kHz and wave length 35 cm. How long will it take to travel 1.5 km? (3)

Ans Given data:

$$f = 20 \text{ kHz} = 20 \times 10^3 \text{ Hz}$$

$$\lambda = 35 \text{ cm} = \frac{35}{100} \text{ m}$$

$$\lambda = 0.35 \text{ m}$$

$$S = 1.5 \text{ km} = 1.5 \times 1000 \text{ m}$$

$$S = 1500 \text{ m}$$

To find:

$$t = ?$$

Solution:

$$v = f\lambda$$

By putting values, we get

$$v = 2 \times 10^3 \times 0.35$$

$$v = 700 \text{ m/s}$$

We know that,

$$S = vt$$

$$t = \frac{S}{v}$$

By putting values, we get

$$t = \frac{1500}{700}$$

$$t = 2.1 \text{ s}$$

Q.6.(a) What are optical fibres? Describe how total internal reflection is used in light propagation through optical fibres. (4)

Ans Optical fibre:

An optical fibre is made by a highly transparent fine strand of glass or plastic coated or cladded with another type of glass whose refractive index is less than the inner tube.

Fibre optics consist of hair sized threads of glass or plastic through which light can be travelled.

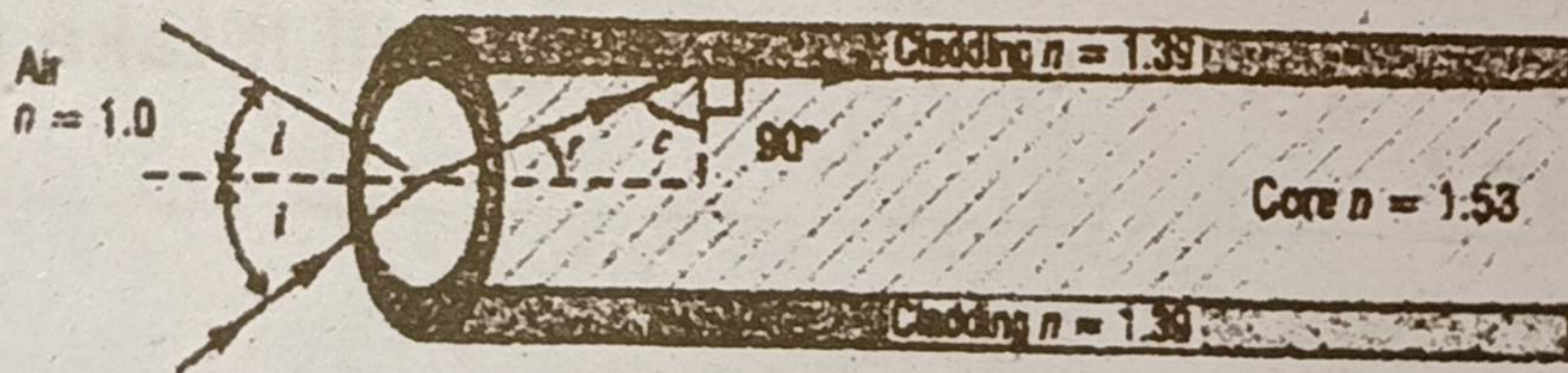

Fig. Passage of light through optical fibre

The inner part of the fibre optics is called core that carries the light and an outer concentric shell is called cladding. The core is made of glass or plastic of relatively high index of refraction. The cladding is made of glass or plastic, but of relatively low refractive index. Light entering from one end of the core strikes the core-cladding boundary at an angle of incidence greater than the critical angle and is reflected back into the core as shown in the

figure above. In this way, light travels many kilometres with small loss of energy.

- (b) The power of a convex lens is 5D. At what distance the object should be placed from the lens so that its real and two time larger image is formed? (3)

Ans Power of lens is:

$$P = 5D$$

Magnification:

$$M = 2$$

Object Distance:

$$P = ?$$

We know:

$$P = \frac{1}{f(m)}$$

$$f = \frac{1}{P}$$

$$f = \frac{1}{5} = 0.2$$

$$f = 20 \text{ m}$$

$$\text{Magnification} = 2 = \frac{I}{O} = \frac{q}{p}$$

$$\Rightarrow \frac{q}{p} = 2$$

$$q = 2p$$

The lens equation:

$$\frac{1}{f} = \frac{1}{p} + \frac{1}{q}$$

By putting given conditions, we get

$$\frac{1}{f} = \frac{1}{p} + \frac{1}{2p}$$

$$\frac{1}{f} = \frac{2+1}{2p}$$

$$\Rightarrow p = \frac{3f}{2}$$

By putting the values, we get

$$p = \frac{3 \times 20}{2}$$

$$p = 30 \text{ cm}$$

Q.7.(a) Discuss the main features of parallel combination of resistors and determine the equivalent resistance also. (4)

Ans Parallel combination of resistors:

In parallel combination of resistors, one end of each resistor is connected with positive terminal of the battery while the other end of each resistor is connected with the negative terminal of the battery. Therefore, the voltage is same across each resistor which is equal to the voltage of the battery. Thus,

$$V = V_1 = V_2 = V_3$$

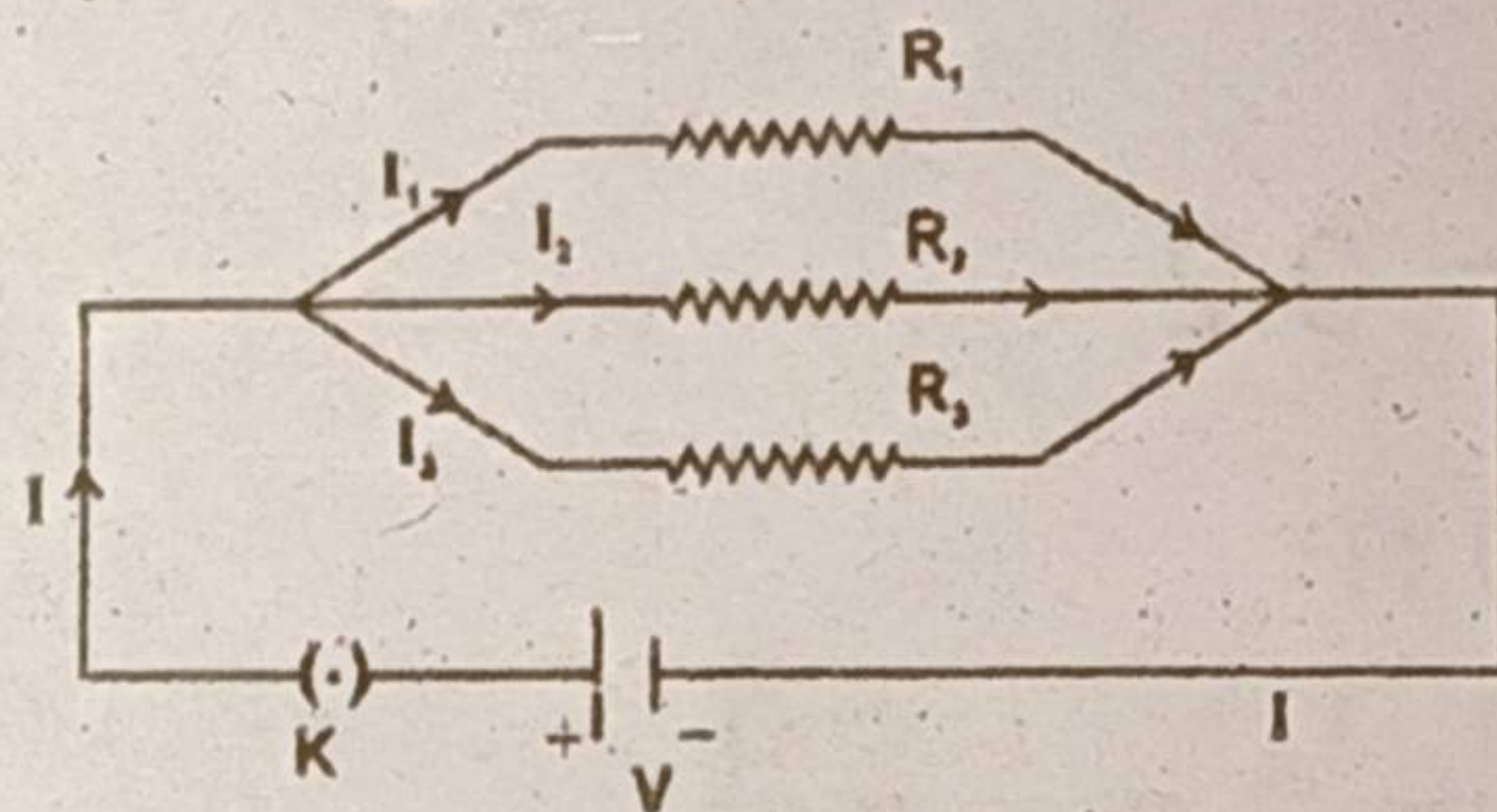

Fig. Three resistors in parallel combination

In parallel circuit, the total current is equal to the sum of the currents in various resistances. Thus,

$$I = I_1 + I_2 + I_3 \quad \dots(1)$$

Since the voltage across each resistance is V, so by Ohm's law

$$I_1 = \frac{V}{R_1}, I_2 = \frac{V}{R_2} \text{ and } I_3 = \frac{V}{R_3}$$

Thus eq. 1 can be written as:

$$I = \frac{V}{R_1} + \frac{V}{R_2} + \frac{V}{R_3}$$

or
$$I = V \left(\frac{1}{R_1} + \frac{1}{R_2} + \frac{1}{R_3} \right) \quad \dots(2)$$

If we replace the combination of resistors with a single resistor called the equivalent resistance R_e such that the same current passes through the circuit. From

Ohm's law $I = \frac{V}{R_e}$. Thus, eq. (2) becomes

$$\frac{V}{R_e} = V \left(\frac{1}{R_1} + \frac{1}{R_2} + \frac{1}{R_3} \right)$$

or
$$\frac{1}{R_e} = \frac{1}{R_1} + \frac{1}{R_2} + \frac{1}{R_3} \quad \dots(3)$$

Thus, the reciprocal of equivalent resistance of a parallel combination is the sum of the reciprocal of the individual resistances, which is less than the smallest resistance of anyone of the resistor connected in this combination. If resistances $R_1, R_2, R_3, \dots, R_n$ are connected in parallel, the equivalent resistance of the combination will be given by:

$$\frac{1}{R_e} = \frac{1}{R_1} + \frac{1}{R_2} + \frac{1}{R_3} + \dots + \frac{1}{R_n}$$

- (b) The potential at a point in an electric field is 10^4 V. If a charge of $+100 \mu\text{C}$ is brought from infinity to this point, what would be the amount of work done on it? (3)

Ans Potential

$$V = 10^4 \text{ V}$$

Charge

$$q = 100 \mu\text{C}$$

$$q = 100 \times 10^{-6} \text{ C}$$

So,

$$W = ?$$

$$V = \frac{W}{q}$$

$$W = Vq$$

$$W = 100 \times 10^{-6} \text{ C} \times 10^4 \text{ V}$$

$$W = 1 \text{ J}$$

Q.8.(a) What is electric motor? Write the principle of D.C. motor. (4)

Ans Electric motor:

"An electric motor converts electric energy into rotational K.E."

Working principle:

It is clear from the figure that the simple coil placed in a magnet cannot rotate more than 90° . The force pushes

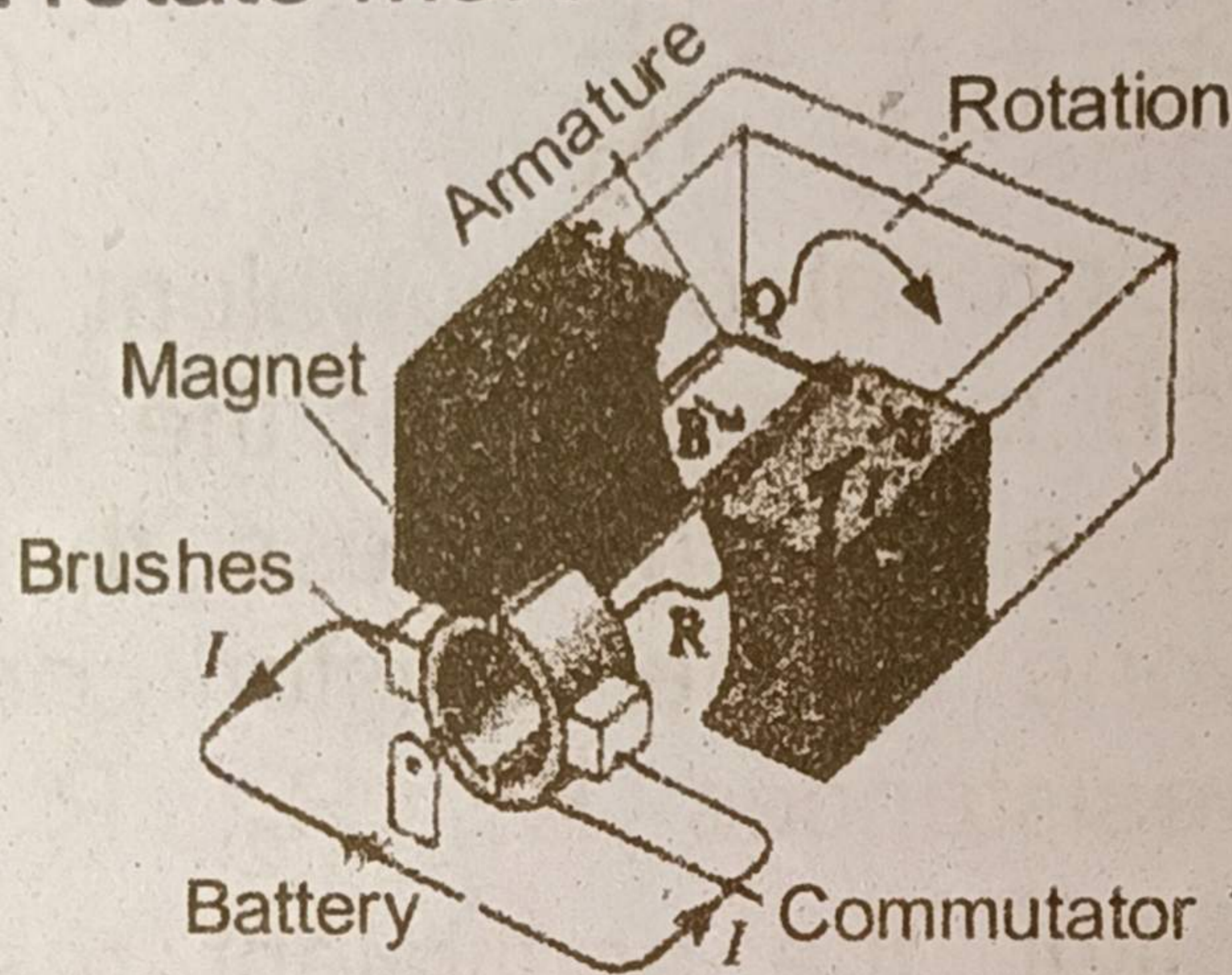

Fig. Working principle of D.C motor.

the PQ side of the coil up and the SR side of the loop down until the loop reaches the vertical position. In this situation, plane of the loop is perpendicular to the magnetic field and the net force on the coil is zero. So the loop will not continue to turn because the forces are still up and down and balanced.

We can rotate the coil continuously by reversing the direction of the current just as the coil reaches its vertical position. This reversal of current will allow the coil to rotate continuously. To reverse direction of current, the connection to coil is made through an arrangement of brushes and a ring that is split into two halves, called a split ring commutator. Brushes, which are usually pieces of graphite, make contact with the commutator and allow the current to flow into the loop. As the loop rotates, so does the commutator. The split ring is arranged so that each half of the commutator changes brushes just as the coil reaches the vertical position. Changing brushes reverse the current in the loop.

As a result, the direction of the force on each side of the coil is reversed and it continues to rotate. This process

repeats at each half-turn, causing the coil to rotate in the magnetic field continuously. The result is an electric motor, which is an apparatus that converts electric energy into rotational kinetic energy.

(b) What is the difference between analogue and digital quantities? Write the two examples of each also. (3)

Ans For Answer see Paper 2015, Group-II, Q.8.(a).

Q.9.(a) Write safety measures to save from hazards of radiations. (4)

Ans We cannot detect radiations directly, we should strictly follow safety precautions, even when the radioactive sources are very weak.

1. The sources should only be handled with tongs and forceps.
2. The user should use rubber gloves and hands should be washed carefully after the experiment.
3. All radioactive sources should be stored in thick lead containers.
4. Never point a radioactive source towards a person.
5. Frequent visits to the radiation sensitive areas should be avoided.

(b) Explain briefly the transmission of radio waves in space. (3)

Ans Electrical signals representing information from a microphone, a TV camera, or a computer can be sent from one place to another place using either cables or radiowaves. Information in the form of audio frequency (AF) signals may be transmitted directly by cable. However, in order to send information over a long distance, it has to be superimposed on electromagnetic waves.

Sr. No.	Li	Lr	$n = \text{-----}$
1	28°	20°	$\frac{\sin 28^\circ}{\sin 20^\circ} = 1.3726$
2	30°	22°	$\frac{\sin 30^\circ}{\sin 22^\circ} = 1.3347$
3	32°	24°	$\frac{\sin 32^\circ}{\sin 40^\circ} = 1.3029$

(ii) Write two laws of reflection of light. (2)

Ans Following are the two laws of reflection of light:

1. The incident ray, the normal, and the reflected ray at the point of incidence, all lie in the same plane.
2. The angle of incidence is equal to the angle of reflection, *i.e.*, $i = r$.

B- If $R_1 = 2k\Omega$, $R_2 = 4k\Omega$ two resistors are connected in series, then find their equivalent resistance? Also draw circuit diagram when resistors are connected to 6V batter. (5)

Ans As we have:

$$R_1 = 2k\Omega$$

$$R_2 = 4k\Omega$$

$$V = 6V$$

Equivalent Resistance:

$$R_e = R_1 + R_2$$

$$R_e = 2K\Omega + 4K\Omega$$

$$R_e = 6k\Omega$$

If current for R_1 , 6V battery install:

$$I_1 = \frac{V}{R_1} = \frac{6V}{2k\Omega}$$

$$I_1 = 3A$$

Current for R_2

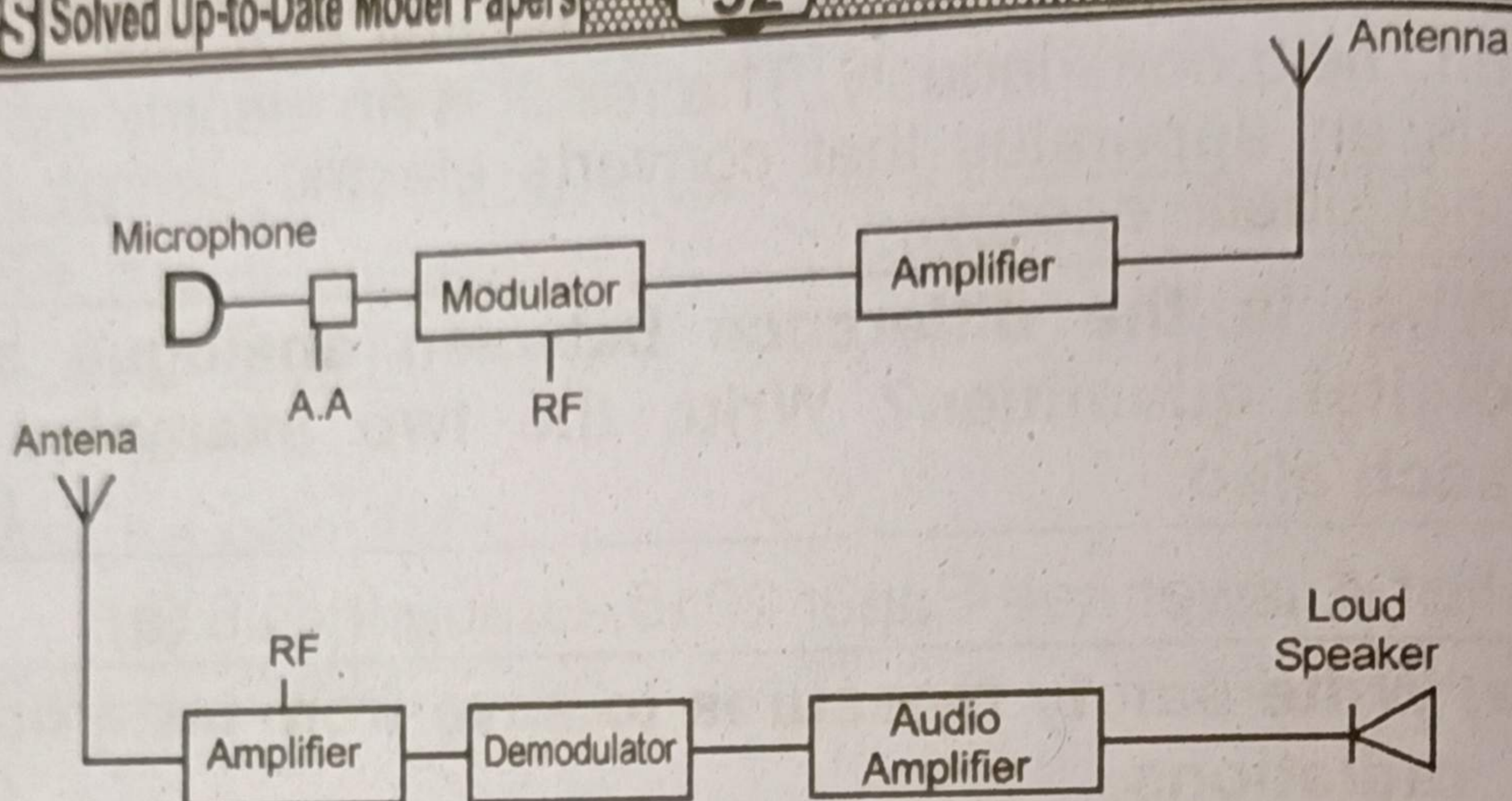

Sound waves produced at the radio station are charged into electrical signals through microphone. These electrical signals are then fall into the transmission antenna which consists of two metal rods. Signals falling on the transmission antenna oscillate the charges which then emit these electrical signals in the form of electromagnetic radiowaves.

At the receiving end, the receiver selects and amplifies the modulated signal. The demodulator then extracts the information signal and delivers it to the receptor.

(Part-III)

(Practical Part)

Note: Attempt any TWO (2) questions.

A-(i) Find refractive index with the help of following table:

Sr. No.	Li	Lr	n = -----
1	28°	20°	-
2	30°	22°	-
3	32°	24°	-

Ans

$$I_2 = \frac{V}{R_2} = \frac{6V}{4k\Omega}$$

$$I_2 = 1.5A$$

Series Circuit Diagram:

The series circuit diagram of resistor is given below:

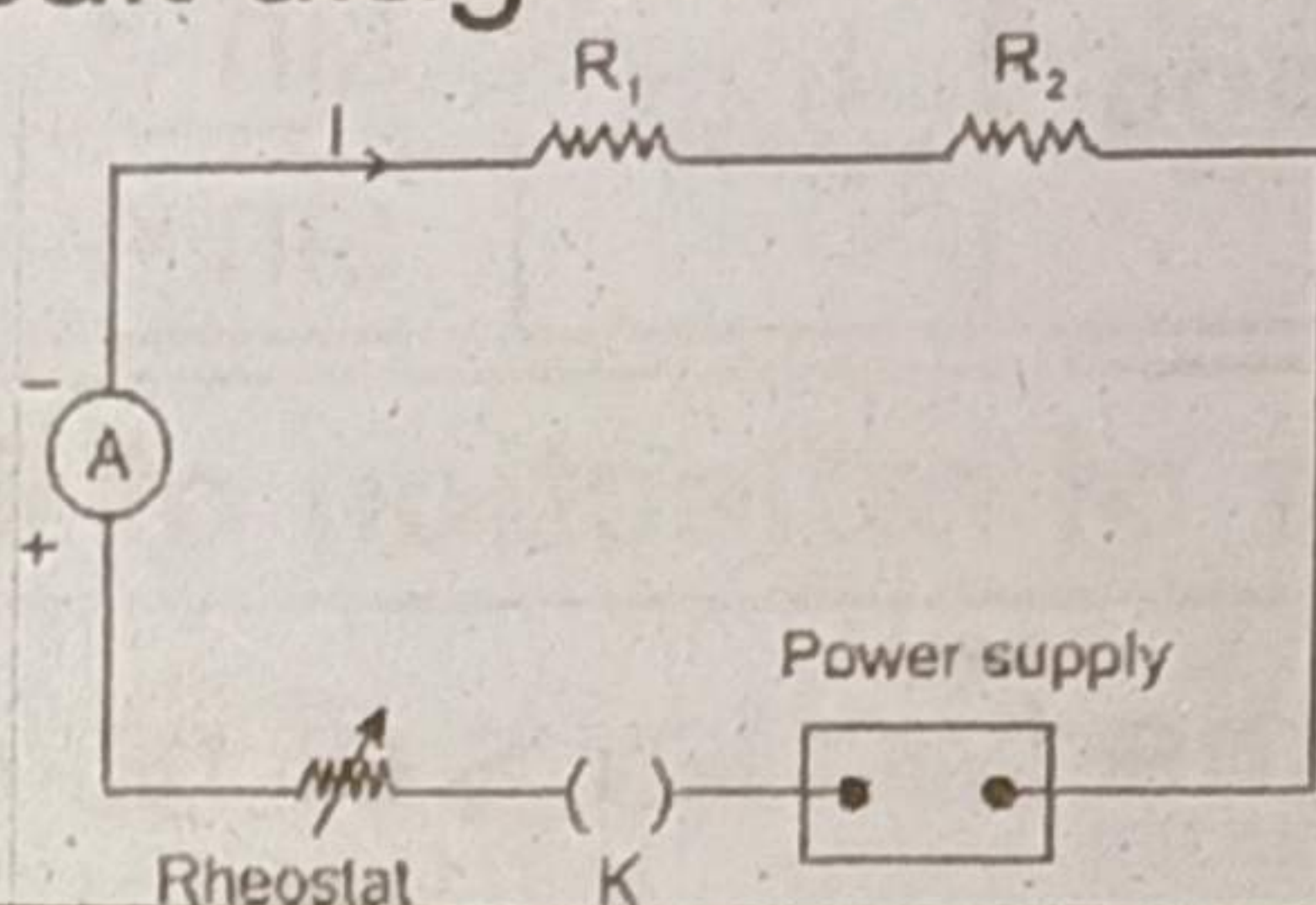

C-(i) Write down truth table and symbol of OR gate. (2)

Ans Table:

The truth table of OR gate is given below:

A	B	X = A + B
0	0	0
0	1	1
1	0	1
1	1	1

Symbol:

The symbol of OR gate is given below:

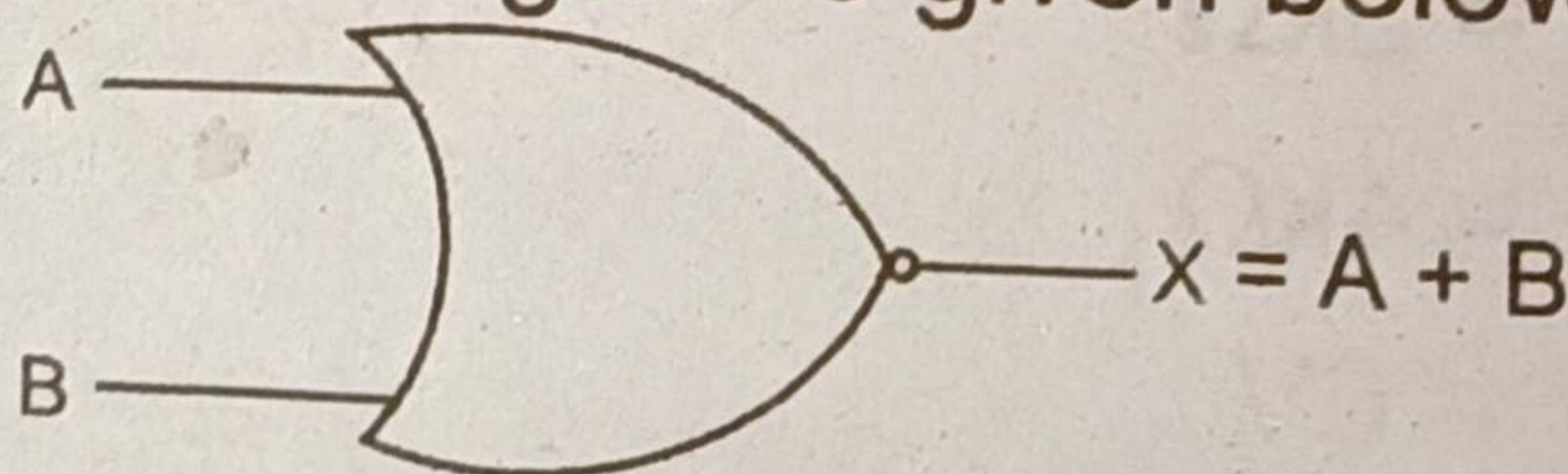

(ii) Define AND Operation, write its formula. (3)

Ans AND Operation may be represented by switches connected in series, with each switch representing an input. When two switches are closed, *i.e.*, the inputs of the AND Operation are at logic '1', the output of AND Operation will be at logic '1'. But when two switches are open, *i.e.*, the inputs of AND Operation are at logic '0', the output of AND Operation will be at logic '0'. For any other state of two switches, the output will be '0'. Its formula is:

$$X = A \cdot B$$